

未注倒角: C1.5

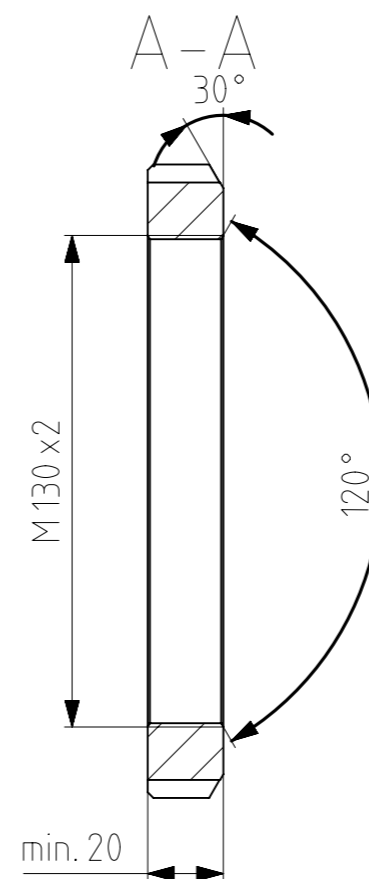
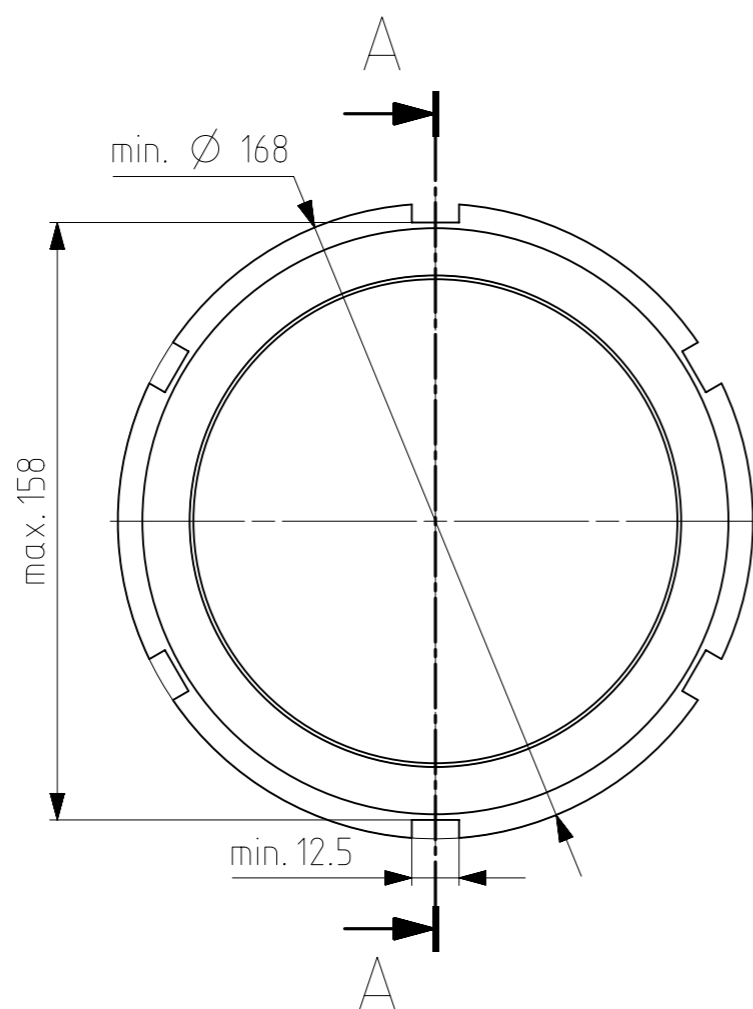

图号: 1464-470-02-22-021

名称: 圆螺母

重量: 1.4 kg

材质: 碳钢(表面发黑)

DESCRIPTION/BENENNUNG				
NUT LOCK BRG GB_T812 M130X2 NUT LOCK BRG GB_T812 M130X2				
DRAWING NO./ZNR.				SCALE/MASSST.
1464-470-02-22-021				1:2
REV. NO./NR.	DOC/DOK. TYP	STAT.	SH. NO./BL. NR.	
00	DRW	FR	1/1	
APPL. STDS/MITG. NORMEN		CREATED BY/ERSTELLT VON		DATE/DATUM
ETR 10009		53000465.SHE		29-11-2021
ISO 8015		MODIFIED BY/GEAENDERT VON		DATE/DATUM
ISO 2768-mK		53000465.SHE		29-11-2021
ISO 1302:2002		COPY FROM/URSPR. ZNR.		MASS/MASSE
		1464-470-12-50-021		1.4 KG
MATERIAL/WERKSTOFF #1	MATERIAL/WERKSTOFF #2	MATERIAL/WERKSTOFF #3		SIZE/FORMAT
				ISO-A3
ACC. TO/GEMAESS	ACC. TO/GEMAESS	ACC. TO/GEMAESS		DO NOT SCALE DRAWING

REPRODUCTION, DISTRIBUTION AND UTILIZATION OF THIS DOCUMENT AS WELL AS COMMUNICATION OF ITS CONTENTS TO OTHERS WITHOUT EXPRESS AUTHORIZATION IS PROHIBITED. OFFENDERS WILL BE HELD LIABLE FOR THE PAYMENT OF DAMAGES. ALL RIGHTS RESERVED. COPYRIGHT (c) WINTEC
WEITERGABE SOWIE VERVIELFÄLTIGUNG DIESES DOKUMENTS, VERWERTUNG UND MITTEILUNG SEINES INHALTS VERBOTEN, SOWEIT NICHT AUSDRUECKLICH GESTATTET. ZUWIDERHANDLUNGEN VERPFLICHTEN ZU SCHADENSERSATZ. ALLE RECHTE VORBEHALTEN. COPYRIGHT (c) WINTEC

WINTEC
MEMBER OF THE ENGEL GROUP

标记	变更内容
1	
2	
3	

版本变更		
版本	变更原因	变更人
00	初版释放	ZHANG
		日期
		2021.11.19

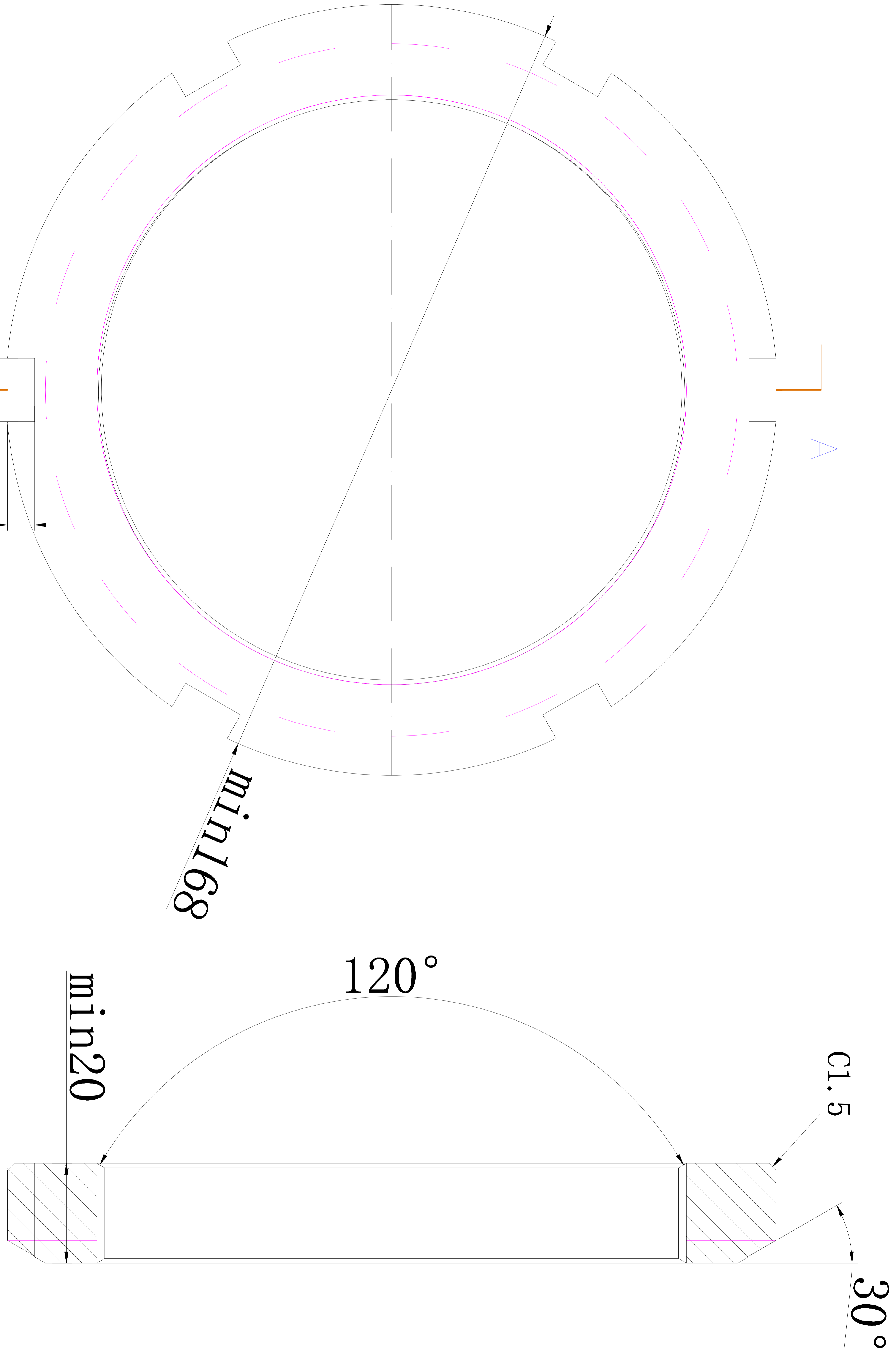

技术要求:
1. 材质碳钢
2. 表面发黑处理

min12.5
min4.5
min16.8
min20
C1.5
30°
120°

DIMENSIONAL TOLERANCES		SCALE: 1 : 1	
.XX	±	0	20
.X	±		
ANGLES	±		
DRAWN	ZHANG		
DATE	2021.11.19		

DO NOT SCALE DRAWING
TITLE:
四槽锁紧圆螺母
PART NO:
E040700

规格描述:

苏州艾奥珂电子有限公司